



Motori elettrici antideflagranti
Flameproof electric motors
Moteurs électriques antidéflagrants
Explosionssgeschützte Elektromotoren
Motores eléctricos antideflagrantes



II 2G, II 2GD • EEx-d, EEx-de

istruzioni di sicurezza
safety instructions
consignes de sécurité
Sichereitsanweisungen
instrucciones de seguridad

cemp

Flameproof
Motors



Atav - Les Ateliers de l'Avre

is a Cemp SpA trademark

cemp

Flameproof
Motors

	Page
1. Introduction	14
2. Installation of flameproof motors ...	14
2.1 Suitability of the motor to the place of installation	14
2.2 Nameplate safety data	15
2.3 Mains	17
2.4 Auxiliary connections	18
2.5 Cable entries	18
2.6 Earthing connection	18
2.7 Further warnings for the installation ...	19
3. Motors without terminals with cable leading out of plate	19
3.1 Motor with plate, armoured cable and cable gland	19
3.2 Motor with plate and free cables	19
4. Motors without fan	20
4.1 Cooling method IC 418	20
4.2 Cooling method IC 410	20
5. Motors with forced ventilation	20
5.1 Cooling method IC 416	20
6. Motors suitable for frequency converter drive	21
7. Inspections and maintenance of flameproof motors	22
8. Repair of flameproof motors	22

Number: SD-2
Edition: 09-05
Replaces: 02-05

1. Introduction

These safety instructions refer to the installation, operation and maintenance of flameproof motors for use in areas where there is a presence of potentially explosive atmospheres.

The flameproof motors have the following protection types against the risk of explosion:

- EEx d IIB/IIIC: flameproof motor and terminal box
- EEx de IIB/IIIC: flameproof motor and increased safety terminal box

Furthermore, motors for environments where combustible dusts (2 GD) are present, have a motor and terminal box with mechanical protection against IP6x dust.

These instructions must be followed in addition to those provided in the instruction manual.

2. Installation of flameproof motors

2.1 Suitability of the motor to the place of installation

Check the motor is suitable to the area classification and the characteristics of the flammable substances present.

European directives 94/9/EC dated 23 March 1994 (relating to equipment) and 1999/92/EC dated 16 December 1999 (relating to plants) establish the essential safety requirements against the risk of explosion in classified areas.

2.1.1 Places subject to the presence of inflammable gas, fumes or mists.

The classification criteria for areas subject to the risk of explosion are laid down in the EN 60079-10 standard.

The technical requirements for electrical plants located in classified areas are established by the EN 60079-14 standard.

The choice of the type of motor, according to these technical and legislative provisions, must take into account the following factors:

- type of plant: mines (group I), above ground plants (group II)
- zone classification: 0, 1, 2 (for which equipment of category 1G, 2G, 3G, respectively are suitable)
- characteristics of the flammable substances present in the form of gases, vapours or fumes:
- sub-group: IIA, IIB, IIC
- temperature class T1, T2, T3, T4, T5, T6 (defines the ignition temperature of the gases)

2.1.2 Places subject to the presence of combustible dust

The criteria for classifying areas at risk of explosion are given in the EN 50281-3 standard.

The criteria for choosing and installing equipment in classified areas subject to dust are given in the EN 50281-1-2 standard.

On the basis of these technical and legislative requirements, the type of motor must be chosen, taking the following factors into account:

- Classification of the area: 20, 21, 22 (equipment of category 1D, 2D, and 3D is suitable respectively).



- Characteristics of inflammable substances in the form of clouds or layers of dust:
- Level of mechanical protection required (IP6x or IP5x).
- Maximum surface temperature allowed.



2.2 Nameplate safety data

In addition to operating data, the information provided on the nameplate, includes:

- information necessary to select the appropriate type of motor and for the correct installation of the motor itself.
- references to the notified bodies responsible for certification.

GB

MARKING MOTORS FOR GASES	
	Mark of conformity to the applicable European directives
	Community mark specifically indicating explosion protection
II 2 G	Motor suitable for above ground plants with the presence of category 2G gases or vapours
EEx d (EEx de)	Flameproof motor with flameproof terminal box Flameproof motor with increased safety terminal box
IIB (IIC)	Container appropriate for substances (gases) in group IIB or IIC
T3 (T4) (T5) (T6)	Motor temperature class (maximum surface temperature)
XYZW xx ATEX yyy	XYZW: laboratory that issued the CE certificate type xx: year in which the certificate was issued yyy: type certificate number
0000	Reference number of the notified body that executed the notification of the production system quality

	MARKING MOTORS FOR DUST
	Mark of conformity to the applicable European directives
	Community mark specifically indicating explosion protection
II GD	Motor suitable for above ground plants with the presence of category 2GD dust
T150 °C (T135 °C) (T100 °C) (T85 °C) (T70 °C)	Maximum motor surface temperature
IP 6x	Mechanical protection level of motor and terminal box
XYZW xx ATEX yyy	XYZW: laboratory that issued the CE type certificate xx: year the certificate was issued yyy: type certificate number
0000	Number of the accredited body that approved the quality of the production system

Notes:

- Group IIC motors are also suitable for environments with substances classified as IIA and IIB. The IIB motors are suitable for environments with IIA classified substances.
- 2G motors are also suitable for areas requiring 3G motors.
- 2GD motors are also suitable for areas requiring 3D motors.
- Motors with a given temperature class are also suitable for all substances with a higher temperature class (for example: T4 motors are suitable for substances with a T3, T2, T1 temperature class).
- If the certificate number indicated on the nameplate is followed by an "X", the user must follow specific conditions of use described in this manual.
- Flameproof motors are normally made to be used at an ambient temperature in the range of $-20\text{ °C} \div +40\text{ °C}$. If the motor has to be employed for operations outside these ambient temperature range, the temperature values must be specified at the time the order is issued and indicated on the nameplate.
- The class of the screws is written on the plate. In case of replacing, screws of the same type must be used (ex: class 8.8 or class 12.9).

2.3 Mains

Connections to the mains must be performed as shown in the wiring diagrams supplied with the motor.

Connection to the power terminal is made, depending on the type of motor, in the sequence indicated in the figures below.

Connections to the main terminals must be executed using the tightening torques indicated below:

SCREW SIZE	TIGHTENING TORQUE [Nm]
M4	1,2
M5	2
M6	3
M8	6
M10	10
M12	15,5

GB

Figure 1 - Connection sequence 56-80
(Aluminium frame)

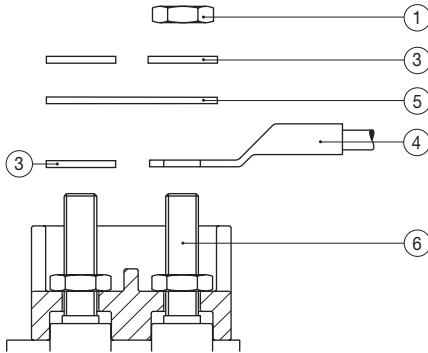

Figure 2 - Connection sequence 63-250
(Cast iron frame)

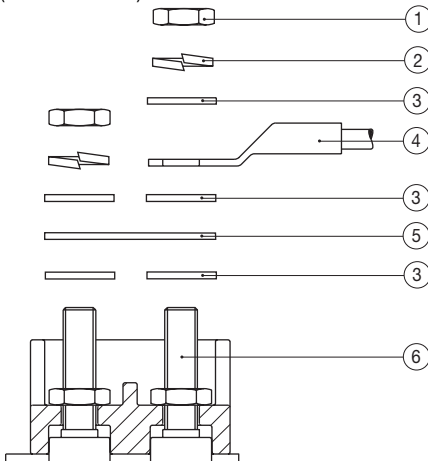
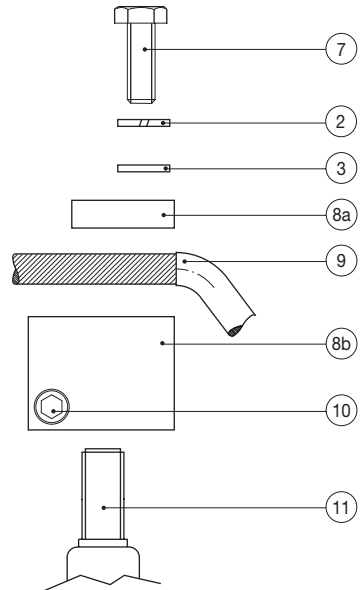

Figure 3 - Connection sequence 280-315
(Cast iron frame)



Legend:

- 1 - Nut
- 2 - Spring washer
- 3 - Flat washer
- 4 - Insulated cable lug.
- 5 - Connecting plate
- 6 - Pin
- 7 - Locking screw
- 8a/8b - Cable fastener terminal
- 9 - Power cable
- 10 - Hexagon-head screw for locking terminal
- 11 - Through pin

The air insulation distances as specified in the EN 50019 standard and indicated in the following table must be maintained when connections are made among conductors having different potential:

RATED VOLTAGE - U [V]	MINIMUM DISTANCE IN AIR [mm]
$175 < U \leq 275$	5
$275 < U \leq 420$	6
$420 < U \leq 550$	8
$550 < U \leq 750$	10
$750 < U \leq 1100$	14

2.4 Auxiliary connections

2.4.1 Thermal protection

With PTC or PT 100 thermistors used for controlling temperature class, the user, in compliance with the essential safety requirements provided for under point 1.5 of the European Directive 94/9EC, must alternatively use:

- use a cut-out in compliance with IEC61508 standard
- use a cut-out that automatically switches to safety position in case of a failure (fail-safe)
- use a dual protection circuit.

2.4.2 Anti-condensation heater

The anticondensation heaters must be feed from a different line from the motor power supply one. Check that the power voltage matches the one indicated on the nameplate. The heaters must not operate when the motor is powered.

Check the type of auxiliary present on the motor by looking at the “auxiliaries marking diagram”.

2.5 Cable entries

Connections must be made via cable or conductor entries in a conduit conforming to the EN 60079-14 standard.

The cable entry must be made without modifying the specific characteristics of the protection type as indicated in the EN 50018 standard (§13.1, 13.2) for EEx-d motors (flameproof protection) and the EN 50019 standard for EEx-de motors (increased safety protection).

When the cable entry is made using a cable gland, the type of cable gland must be selected correctly in relation to the type of plant and the type of cable.

The cable gland must be tightened fully until the seal rings ensure the necessary pressure:

- to prevent transmission of mechanical stress to the motor terminals
- to ensure the mechanical protection (degree) of the terminal box.

Cable entries for EEx-d terminal boxes must consist of seal bushings or EEx-d cable glands certified according to the EN 50014, EN 50018 Standards and the ATEX Directive (94/9/CE). Furthermore, they must have a minimum IP55 protection class (IP65 for the GD category).

EEx-e cable glands certified according to the EN 50014, EN 50019 and the ATEX directive must be used for the EEx-de terminal boxes. Furthermore, they must have a minimum IP55 protection class (IP65 for the GD category).

The blocking fitting and cable must be selected on the basis of the maximum operating temperature required for the cable, and indicated on the warning plate if over 70°C.

Gaskets must not be added, unless supplied by the manufacturer.

Unused cable entries must be closed with certified caps.

2.6 Earthing connection

Flameproof motors are provided with two earthing terminals: one inside the terminal box and the other on the motor frame. Depending on the cross-section of the line conductor, the earthing conductor cross-section must be:

LINE CONDUCTOR SECTION	EARTH CONDUCTOR SECTION
Less than or equal to 16 mm ²	Same section
Between 16 mm ² and 35 mm ²	16
Greater than 35 mm ²	Greater than or equal to 50% of the section

2.7 Further warnings for the installation

Flameproof motors must be protected against overloads with automatic power supply disconnection by using a countdown protection device or by using a device to control directly the temperature by means of temperature sensors inserted in the windings. It is necessary to ensure that the motor ventilation is not impaired by obstacles positioned in the surrounding area when flameproof motors are installed. For this purpose a minimum distance must be maintained between the motor and any device that is not part of the motor, according to the following table:

SIZE	MINIMUM DISTANCE FROM OTHER DEVICES [mm]
up to 160	40
from 180 to 225	85
≥ 250	125

The terminal board box must always be closed before starting the motor.

Lightly re-grease machined flamepath surfaces, fit terminal box lid and tighten fixing bolts to torques as indicated in table.

TIGHTENING TORQUES [Nm]						
Aluminium frame						
Steel class	M4	M5	M6	M8		
8.8 (A4-80)	2	3.2	5	12		
12.9	3	4.8	7.5	18		
Cast iron frame						
Steel class	M4	M5	M6	M8	M10	M12
8.8	2.9	5.6	10	23	35	80

3. Motors without terminal box with cable leading out of plate

When the motor comes without a terminal box, the motor's enclosure is closed with a plate with the power supply cable leading out of it. To install correctly, the user must follow the instructions below.

3.1 Motor with plate, armoured cable and cable gland

GB

An armoured cable leads out of the motor plate clamped by an appropriate cable gland.

Free cables lead out of the motor plate featuring the clamping coupling, and are used to supply the motor. The user must protect power supply cables from potential damage arising from mechanical stress, and must connect ends of cables according to one of the safety methods provided for by standard EN50014-1997, in conformity with engineering rules in force for the place where the motor is to be used.

Should the motor come complete with coupling and flexible tube, the user must connect the end of the wires directly onto the terminals located in the relevant box.

3.2 Motor with plate and free cables

In this case the user must close the case with a locking joint, as described in the point above.

4. Motors without fan

4.1 Cooling method IC 418

Ventilation is supplied by a fan directly coupled to the motor. Ensure that the motor ventilation is not impaired in all operating conditions and that the temperature limits allowed by the insulation category B are complied with.

Fans must comply with the EN 1127-1 standard and any possible product standards referring to fans.

In areas with combustible dusts, the provisions of the EN 50281-1-1 standard must be observed.

4.2 Cooling method IC 410

The motor is without a fan. The following limitations must be observed:

- For "S1" operation, the motor power output is derated by 50% to comply with the limits allowed by insulation class B.
- For "S2" operation, regular power output can be used provided the motor does not work long enough for it to reach the temperature limits of insulation class B. Said time limits are indicated on the plate.

5. Motors with forced ventilation

5.1 Cooling method IC 416

Cooling is assured by ventilation provided by an auxiliary flameproof motor, covered by separate certification, fitted on the back of the main motor.

The user must have a safety device fitted enabling the main motor to be started only once the auxiliary motor is running.

In addition, motors must be equipped with PTC or PT100 thermal probes, which must be connected with a cut-out disconnecting the motor's power supply. This cut-out must not have a manual reset.

6. Motors suitable for frequency converter drive

For operation with an inverter, motors must be equipped with PTC or PT100 thermistors inserted in the winding to ensure compliance with the limits of the temperature class.

If the motor temperature class is T4, the user must connect the PTC or PT100 terminals to a tripping relay ensuring that the power supply is cut off whenever a dangerous temperature is reached. The reset of said cut-out must be performed manually only, and not automatically.

The user, in compliance with the essential safety requirements provided for under point 1.5 of European Directive 94/96 EC, must:

- use a cut-out in compliance with IEC 61508 standard

or

- use a cut-out that automatically switches to safety position in case of a failure (fail-safe)

or

- use a dual protection circuit. As an alternative, the user can employ a dual device such as that indicated in section 5 for forced ventilation.

When temperature class T5 or T6 the condition for use is indicated on the certificate.

Rated performance relating to operation at mains power frequency cannot be maintained if powered by an inverter. In particular, power output could be significantly reduced to maintain the assigned temperature class and to avoid damage caused by overheating.

Inverter motors have an auxiliary plate. Before starting the motor, check the ratings (kW – Hz – torque) indicated on the auxiliary plate. The user must contact the manufacturer if this information is not provided.

Induction motors supplied from the mains conform to the immunity and emission limits relating to electromagnetic compatibility as foreseen by the standards.

When power is supplied by a frequency converter, the installer bears responsibility for checks and any measures required to comply with immunity and emission limits as laid down by the standards.

The choice of the type of frequency converter must be made taking into account that the motor must not be subjected to voltage peaks exceeding 1100 V, which would significantly reduce the life of the windings insulation. It is necessary to consider in this respect that the voltage peaks value is also influenced by the length of the power supply cable.

When the motor does not come with forced ventilation provided by an auxiliary motor, motors with IC416 cooling, the user must follow instructions given in point 5.1 (Cooling method IC416).

GB

7. Inspections and maintenance of flameproof motors

The inspections and maintenance of flameproof motors shall be executed in compliance with the criteria of the EN 60079-17 standard.

The electrical connection terminals must be tightened fully to avoid high contact resistances and consequential overheating.

Care must be taken to ensure that the insulation distances in air and on the surfaces between the conductors are maintained, as established by the standards.

All bolts used to secure both motor and terminal box must be tightened using the torque values as indicated in the table TIGHTENING TORQUES par. 2.7. All screws utilised to seal the motor and the terminal board shall be tightened fully.

Replacement of gaskets and cable entry parts shall be executed using components that are identical to the components supplied by the manufacturer to ensure the protection degree is maintained.

The surfaces of flameproof joints must not be machined and sealing gaskets different from those supplied by the manufacturer must not be inserted. These surfaces must be maintained in a clean condition. A thin layer of non-hardening grease must be used against corrosion and to prevent water from entering. This grease layer must be renewed at every disassembly.

8. Repair of flameproof motors

Repairs made to flameproof motors shall be executed in compliance with the criteria specified in the IEC 60079-19 standard.

If repairs are not executed by the manufacturer, they must be carried out at workshops which have the necessary equipment and with adequate technical expertise concerning the motor protection types.

If repair work has to be performed on parts that influence the flameproof protection characteristics the motor construction data must not be changed (for example: dimensions of joints, windings characteristics, etc.) and the repaired parts must be tested.

A written report must be prepared with the detailed indication of the work carried out.

If after the repair work has been completed, the motor complies entirely with the standard and with the certificate, an additional nameplate shall be affixed to the motor (without removing the original nameplate) showing the following marks:

- Symbol **R**
- name or trademark of the repairer
- serial number given to the repair operation by the repairer
- date of repair

If following a repair that modifies relevant aspects concerning protection against explosions, the motor does not comply with the certificate, the original nameplate must be removed and the motor can no longer be considered suitable for use in areas where there is danger of explosion.

In order to be utilised in such areas the motor must be examined again by a competent certification body.

Programma di vendita	Sales programme	Programme	Lieferprogramm	Programa de venta
Motori antideflagranti EEx-d - EEx-de <ul style="list-style-type: none"> • gruppo I-IIA-IIB-IIC • categoria M2, 2G, 2D, 2GD • classe T3-T4-T5-T6 • trifasi, monofasi • con freno 	Flameproof motors EEx-d - EEx-de <ul style="list-style-type: none"> • group I-IIA-IIB-IIC • category M2, 2G, 2D, 2GD • class T3-T4-T5-T6 • threephase, singlephase • with brake 	Moteurs antidéflagrants EEx-d - EEx-de <ul style="list-style-type: none"> • groupe I-IIA-IIB-IIC • catégorie M2, 2G, 2D, 2GD • classes de température T3-T4-T5-T6 • triphasés, monophasés • avec frein 	Explosionsgeschützte Motoren EEx-d - EEx-de <ul style="list-style-type: none"> • Gruppe I-IIA-IIB-IIC • Kategorie M2, 2G, 2D, 2GD • Klasse T3-T4-T5-T6 • Dreiphasen- und Einphasen-Ausführung • mit Bremse 	Motors antideflagrantes EEx-d - EEx-de <ul style="list-style-type: none"> • grupo I-IIA-IIB-IIC • categoría M2, 2G, 2D, 2GD • classe T3-T4-T5-T6 • trifásicos, monofásicos • con freno
Motori a sicurezza aumentata EEx-e <ul style="list-style-type: none"> • gruppo II • categoria 2G • classe T1-T2-T3 	Increased safety motors EEx-e <ul style="list-style-type: none"> • group II • category 2G • class T1-T2-T3 	Moteurs à sécurité augmentée EEx-e <ul style="list-style-type: none"> • groupe II • catégorie 2G • classes de température T1-T2-T3 	Motoren in Schutzart "erhöhte Sicherheit" EEx-e <ul style="list-style-type: none"> • Gruppe II • Kategorie 2G • Klasse T1-T2-T3 	Motors de seguridad aumentada EEx-e <ul style="list-style-type: none"> • grupo II • categoría 2G • clase T1-T2-T3
Motori non sparking EEx-nA <ul style="list-style-type: none"> • gruppo II • categoria 3G, 3GD 	Non sparking motors EEx-nA <ul style="list-style-type: none"> • group II • category 3G, 3GD 	Moteurs anti-étincelle EEx-nA (non sparking) <ul style="list-style-type: none"> • groupe II • catégorie 3G, 3GD 	Funkenfreie Motoren EEx-nA <ul style="list-style-type: none"> • Gruppe II • Kategorie 3G, 3GD 	Motors no sparking EEx-nA <ul style="list-style-type: none"> • grupo II • categoría 3G, 3GD
Motori chiusi con ventilazione esterna CEI/IEC <ul style="list-style-type: none"> • trifasi, monofasi • categoria 3D 	Totally enclosed fan cooled IEC motors <ul style="list-style-type: none"> • threephase, singlephase • category 3D 	Moteurs IP 55 CEI-IEC avec ventilation extérieure <ul style="list-style-type: none"> • triphasés, monophasés • catégorie 3D 	Vollgekapselte luftgekühlte Motoren nach IEC <ul style="list-style-type: none"> • Dreiphasen- und Einphasen-Ausführung • Kategorie 3D 	Motors cerrados con ventilación exterior IP 55 CEI/IEC <ul style="list-style-type: none"> • trifásicos, monofásicos • categoría 3D
Elettropompe centrifughe antideflagranti per macchine da stampa EEx-d - EEx-de	Centrifugal flameproof electric pumps for printing machines EEx-d - EEx-de	Elettropompes centrifuges antideflagrantes pour machines d'imprimerie EEx-d - EEx-de	Explosionsgeschützte Zentrifugal-Elektropumpen für Druckmaschinen EEx-d - EEx-de	Electrobombas centrifugas para máquinas de impresión EEx-d - EEx-de
Elettropompe centrifughe per macchine utensili	Centrifugal electric pumps for machine tools	Elettropompes centrifuges pour machines-outils	Elektropumpen für Werkzeugmaschinen	Electrobombas centrifugas para máquinas herramientas

Nel redigere questa documentazione è stata posta ogni cura al fine di assicurare la correttezza delle informazioni contenute.

Tuttavia, anche in conseguenza della politica di continuo sviluppo e miglioramento della qualità del prodotto perseguita da **Cemp**, la società si riserva il diritto e la facoltà di apportare modifiche di qualsiasi genere, in qualsiasi momento e senza preavviso, sia a questo documento sia ai propri prodotti.

Le descrizioni e le caratteristiche tecniche della presente pubblicazione non sono quindi impegnative e i dati riportati non costituiscono, in nessun caso, impegno contrattuale.

Every care has been taken to ensure the accuracy of the information contained in this publication.

Due to **Cemp's** policy of continuous development and improvement, the company reserves the right to supply products which may differ slightly from those illustrated and described in this publication.

Descriptions and technical features listed in this brochure may not be considered as binding. Under no circumstances should data in this publication be considered as a contractual obligation.

Dans la préparation de cette documentation nous avons pris le soin d'y intégrer les informations les plus exactes possibles.

Néanmoins, compte tenu de notre politique de développement et d'amélioration continue des produits, la Société **Cemp** se réserve le droit et la faculté d'apporter toute modification sur la documentation et sur les produits, à tout moment et sans préavis.

Les descriptifs et les caractéristiques techniques contenus dans ce catalogue n'engagent pas la Société. Par conséquent, ces données ne constituent en aucun cas un engagement contractuel.

Die Ausführungen und technischen Eigenschaften, die in dieser Broschüre angegeben sind, dürfen nicht als verbindlich angesehen werden.

In keinem Fall können jedoch die in diesem Dokument aufgeführten technischen Daten als rechtlich verbindlich angesehen werden.

Cemp behält sich das Recht vor, ohne Mitteilung, jegliche Abweichungen und Änderungen jederzeit vorzunehmen, sowohl in diesem Dokument als auch bei den Produkten, die hier beschrieben sind.

La presente documentación se ha redactado de manera muy atenta para poder asegurar que las informaciones que contiene son correctas.

No obstante, como consecuencia de la política de continuo desarrollo y mejora de la calidad del producto que **Cemp** pone en práctica, la sociedad se reserva el derecho y la facultad de modificar en lo que fuera necesario, en cualquier momento y sin que para ello medie preaviso alguno, tanto este documento como sus productos.

Por lo tanto, las descripciones y las características técnicas indicadas en el presente documento no son vinculantes, y los datos que contiene no constituyen en ningún caso, vínculo contractual.

Cemp SpA

Via Piemonte, 16
I 20030 SENAGO (MI)
Tel. +39 02 99 01 08 04
Fax +39 02 99 89 177
cemp@cemp.it
www.cemp.it

Cemp France sa

6 et 8, avenue Victor Hugo
F 27320 NONANCOURT
Tél. +33 (0)820 031 310
Fax +33 (0)820 031 816
cemp-france@cemp.it
www.cemp-international.com

Cemp International GmbH

Am Mollnhof 2
D 94036 PASSAU
Tel. +49 (0)851 96 68 68 28
Fax +49 (0)851 96 68 68 29
cemp-deutschland@cemp.it
www.cemp-international.com

Cemp Great Britain - Service Center

41 Half House Lane - BRIGHOUSE
West Yorkshire - HD6 2PH
Tel. +44 (0)7929 002 038
Fax +44 (0)1484 722 122
cemp-greatbritain@cemp.it
www.cemp-international.com

Overall sales network at www.cemp.it
